

10000 Ambient Air Monitor

0.1 CFM (2.83 LPM)



The Particles Plus® 10000 is designed for outdoor particulate and gas monitoring. These robust monitors provide reliable, accurate measurement of airborne contamination allowing for the detection of environmental and public health concerns. The first real time monitor to provide 6 accurate particulate size channels.

Real-Time Data

6 particle size channels recorded by the 10000 Monitor are stored in an internal non-volatile memory at user-defined data sampling rates (1 second to 99 hours). The high time-resolution of the Model 10000 measurements provides a near-instantaneous look at changing airborne particulate concentrations, leading to a well-defined model of local point source influences that may disproportionately affect air quality.

Internet-Enabled

Particles Plus® systems are configured to allow users to push real-time data to the cloud where sensor outputs can be visualized by authorized stakeholders.

Fully Integrated Environmental Sensor System

Integration of additional sensors for measurement of environmental and meteorological parameters (relative humidity, temperature, barometric pressure, (optional) carbon dioxide – CO₂, and total volatile organic compounds – TVOC) offers a more complete view of air quality.

Applications

- Airborne Pollution and Environmental Research
- Perimeter or Fence-line Monitoring for Construction, Remediation or Waste Sites
- Mine and Quarry Fence-line Monitoring for dust control operations
- City Wide or Community Air Pollution Monitoring
- Roadside Emissions Monitoring
- Medical Facilities Property Monitoring
- Power Line Wild-Fire Monitoring
- Environmental Disasters
- Monitor for 24 hours a day, 7 days a week, 365 days a year

Features and Benefits

- Concurrent measurement of multiple, user selectable PM sizes from 0.3 µm to 10 µm including TPM of particles up to 25.0 µm
- Closed-loop humidity control for incoming air stream (to provide more accurate particulate sizing)
- Closed-loop condensation control within the enclosure
- Perform in-line gravimetric sample collection for correction reference calibration
- ULTRAGUARD® Fiberglass reinforced polyester NEMA 4 rated outdoor tamper-proof enclosure with internal thermal control
- Optional pole or tripod mount options
- Optional Cloud based data management software subscription available for remote

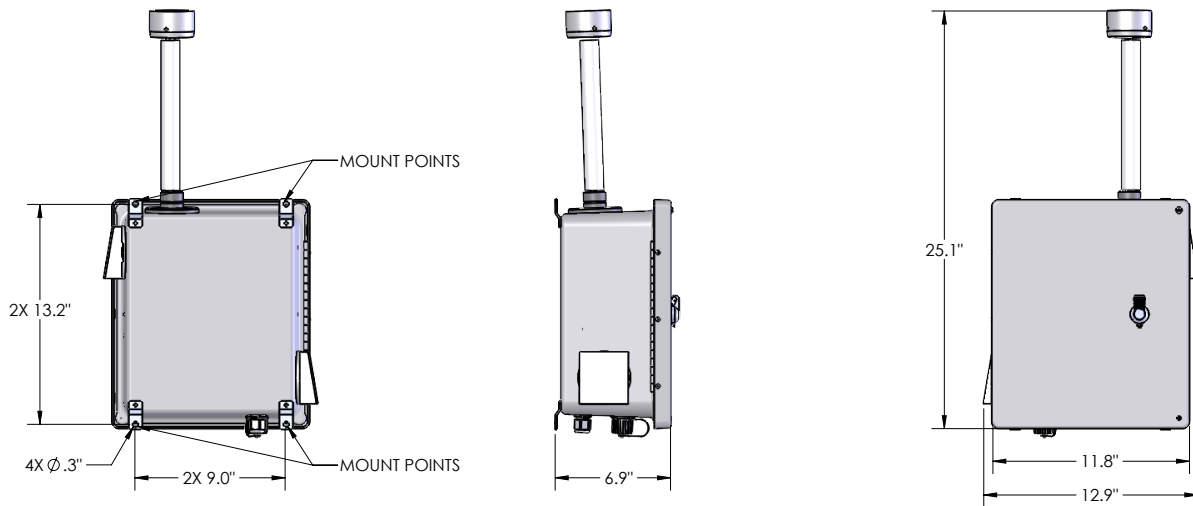

Specifications

Model	10000
Size Range	0.3 to 25 µm
Size Channels	Factory calibrated at 0.3, 0.5, 1.0, 2.5, 5.0, 10.0 µm
Flow rates / Accuracy	0.1 CFM (2.83 LPM) / ± 3%
Aerosol Concentration Range	0.01 to 20,000 µg/m ³
Light Source	Long life laser diode
Resolution	0.00003 µg/m ³
Zero Stability	No appreciable drift
Count Modes	Real-Time Meter and graph, cumulative/differential count/m ³ and count/ft ³ , and mass concentration (PM)
Log Interval	Minimum 1 second with no hold time, maximum 99 hours
Calibration	NIST traceable
Display	4.3" (10.9 cm) WQVGA (480×272) color touch screen
Vacuum Source	Internal pump with automatic flow control
Filtered Exhaust	Internal HEPA filter
Number of Channels	6
Custom Size Channels	Calibration for custom size channels available
Environmental Sensor	Temperature and relative humidity probe: -4° to 122°F (-20° to 50°C) ±1°F (0.5°C), 0 -100% ± 2%RH
Optional Sensors	NDIR CO ₂ (0-5000 ppm, resolution 1 ppm, accuracy ±1% FS, Response rate 20 seconds) TVOC PID, 0-50 ppm / min. detection level 5 ppb, accuracy ±1.5%, Response rate <3 seconds
Alarm	Alarms for all particle values, environmental sensors, flow and sensor failure
Calibration	Particle sensor recommended once per year
User Calibration	Field Calibration of Temperature, Humidity, CO ₂ and TVOC possible with included utility software
External Surface	ULTRAGUARD® Fiberglass reinforced polyester - compression molded SMC box and Cover
Dimensions (L x W x H)	12.85" x 7.41" x 25.54" (32.7 cm x 18.9 cm x 64.9 cm) includes barb fittings
Weight	12.5 lbs. (5.66 kg)
Accessories	Quick start guide, operating manual on USB flash drive, mounting feet
Optional Accessories	Printed manual, data cable, pole mounting hardware kit
Data Storage	Internal 45,000 sample records (rotating buffer) including particle count data and environmental data
Power	110 to 240 VAC 50/60 Hz universal in-line power supply
Operating Conditions	-4° to 122°F (-20° to 50°C) / 20% to 95% non-condensing
Warranty	2 year limited warranty. Extended warranties available